

Notch tools

Inserts	E.02
Notch tools	E.04
Technical data	E.08

Notch tools

Automatic lathes

Ceramic tools

Threading

Cartridges

Square shoulder cut.

Profile milling

Face milling

Slot cutters

Drilling & boring

Tooling

- Inserts
- General turning
- Parting & grooving
- Notch tools

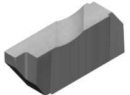
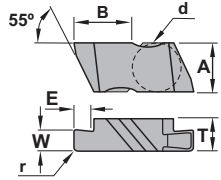
 NG									Normally available for immediate delivery ● Only available in a limited quantity ○							
	d	A	B	E	r	T	W	KM15	PM25	PM40	TIN16	TIN17	TIN22	TIN32	ZR10	
	NG-2031R/L	0.187	0.219	0.270	0.050	0.002	0.150	0.031				○				
	NG-210R/L	0.187	0.219	0.270	0.050	0.002	0.150	0.039				○				
	NG2041R/L	0.187	0.219	0.270	0.050	0.002	0.150	0.041				○				
	NG2047R/L	0.187	0.219	0.270	0.050	0.002	0.150	0.047				○				
	NG2058R/L	0.187	0.219	0.270	0.050	0.002	0.150	0.058				○				
	NG2062R/L	0.187	0.219	0.270	0.110	0.002	0.150	0.062				○				
	NG220R/L	0.187	0.219	0.270	0.110	0.002	0.150	0.080				○				
	NG2094R/L	0.187	0.219	0.270	0.110	0.002	0.150	0.094				○				
	NG230R/L	0.187	0.219	0.270	0.110	0.002	0.150	0.119				○				
	NG2125R/L	0.187	0.219	0.270	0.110	0.002	0.150	0.125				○				
	NG3031R/L	0.375	0.344	0.405	0.050	0.002	0.195	0.031				○				
	NG310R/L	0.375	0.344	0.405	0.050	0.002	0.195	0.039				○				
	NG3047R/L	0.375	0.344	0.405	0.075	0.002	0.195	0.047				○				
	NG3062R/L	0.375	0.344	0.405	0.120	0.005	0.195	0.062				○				
	NG3072R/L	0.375	0.344	0.405	0.120	0.005	0.195	0.072				○				
	NG3078R/L	0.375	0.344	0.405	0.120	0.005	0.195	0.078				○				
	NG320R/L	0.375	0.344	0.405	0.120	0.005	0.195	0.079				○				
	NG3088R/L	0.375	0.344	0.405	0.120	0.005	0.195	0.088				○				
	NG3094R/L	0.375	0.344	0.405	0.180	0.005	0.195	0.094				○				
	NG3105R/L	0.375	0.344	0.405	0.180	0.005	0.195	0.105				○				
	NG3110R/L	0.375	0.344	0.405	0.180	0.005	0.195	0.110				○				
	NG330R/L	0.375	0.344	0.405	0.180	0.005	0.195	0.122				○				
	NG3122R/L	0.375	0.344	0.405	0.180	0.005	0.195	0.122				○				
	NG3125R/L	0.375	0.344	0.405	0.180	0.005	0.195	0.125				○				
	NG3142R/L	0.375	0.344	0.405	0.180	0.005	0.195	0.142				○				
	NG3156R/L	0.375	0.344	0.405	0.180	0.005	0.195	0.156				○				
	NG340R/L	0.375	0.344	0.405	0.180	0.005	0.195	0.158				○				
	NG3178R/L	0.375	0.344	0.405	0.180	0.005	0.195	0.178				○				
	NG3185R/L	0.375	0.344	0.405	0.180	0.020	0.195	0.185				○				
	NG3189R/L	0.375	0.344	0.405	0.180	0.020	0.195	0.189				○				
	NG4125R/L	0.375	0.453	0.636	0.250	0.005	0.255	0.125				○				
	NG4189R/L	0.375	0.453	0.636	0.250	0.020	0.255	0.189				○				
	NG450R/L	0.375	0.453	0.636	0.250	0.010	0.255	0.197				○				
	NG4213R/L	0.375	0.453	0.636	0.250	0.005	0.255	0.213				○				
	NG4219R/L	0.375	0.453	0.636	0.250	0.020	0.255	0.219				○				
NG4250R/L	0.375	0.453	0.636	0.250	0.020	0.255	0.250				○					
NG4312R/L	0.375	0.453	0.636	0.250	0.030	0.255	0.312				○					
NG6281R/L	0.375	0.453	0.636	0.250	0.030	0.383	0.281				○					
NG6312R/L	0.375	0.453	0.636	0.250	0.030	0.383	0.319				○					
NG6375R/L	0.375	0.453	0.636	0.250	0.030	0.383	0.375				○					

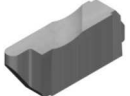
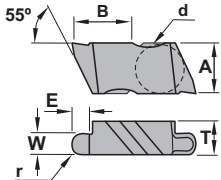
 NR									Normally available for immediate delivery ● Only available in a limited quantity ○							
	d	A	B	E	r	T	W	KM15	PM25	PM40	TIN16	TIN17	TIN22	TIN32	ZR10	
	NR2031R/L	0.187	0.219	0.268	0.110	0.031	0.150	0.062				○				
	NR2047R/L	0.187	0.219	0.267	0.110	0.047	0.150	0.094				○				
	NR2062R/L	0.187	0.219	0.266	0.110	0.062	0.150	0.125				○				
	NR3031R/L	0.375	0.344	0.403	0.150	0.031	0.195	0.062				○				
	NR3047R/L	0.375	0.344	0.402	0.150	0.047	0.195	0.094				○				
	NR3062R/L	0.375	0.344	0.401	0.150	0.062	0.195	0.125				○				
	NR3078R/L	0.375	0.344	0.400	0.150	0.078	0.195	0.156				○				
	NR3094R/L	0.375	0.344	0.400	0.150	0.094	0.195	0.188				○				
	NR4062R/L	0.375	0.453	0.632	0.250	0.062	0.255	0.125				○				
	NR4094R/L	0.375	0.453	0.394	0.250	0.094	0.255	0.188				○				
	NR4125R/L	0.375	0.453	0.630	0.250	0.125	0.255	0.250				○				

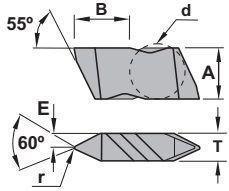

Normally available for immediate delivery ●
Only available in a limited quantity ○

NT		d	A	B	E	r	T	KM15	PM25	PM40	TIN16	TIN17	TIN22	TIN32	ZR10
	NT2R/L	0.187	0.219	0.266	0.075	0.003	0.150				○				
	NT3R/L	0.375	0.344	0.400	0.098	0.005	0.195				○				
	NT4R/L	0.375	0.453	0.629	0.128	0.005	0.255				○				

Notch tools

Automatic lathes

Ceramic tools

Threading

Cartridges

Square shoulder cut.

Profile milling

Face milling

Slot cutters

Drilling & boring

Tooling

- Inserts
- General turning
- Parting & grooving
- Notch tools

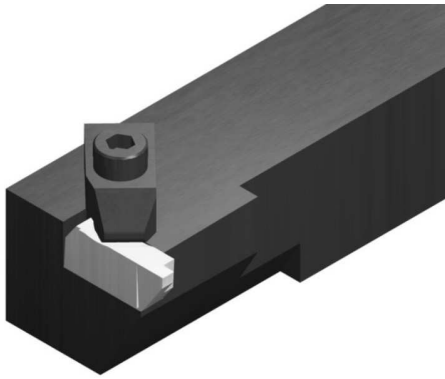

Characteristics:

Multipurpose grooving and threading top clamp toolholder. Right tools require left inserts and vice versa. Maximum grooving depth depending on insert.

Applications:

External/internal grooving toolholder.

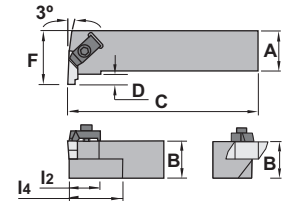

NE		POSITIVE RAKE							Insert size	
Ref.		A	B	l ₂	C	l ₄	D	F		
	NE R/L 062	0.375	0.375	0.500	2.5	1.000	0.138	0.750	N.. 2	0.154
	NE R/L 082J	0.500	0.500	0.500	3.5	1.000	0.138	0.750	N.. 2	0.220
	NE R/L 102B	0.625	0.625	-	4.5	1.000	0.138	0.750	N.. 2	0.440
	NE R/L 122B	0.750	0.750	0.500	4.5	1.000	0.138	1.000	N.. 2	0.880
	NE R/L 123B	0.750	0.750	0.750	4.5	2.000	0.210	1.125	N.. 3	0.880
	NE R/L 163D	1.000	1.000	0.750	6.0	2.000	0.210	1.250	N.. 3	1.540
	NE R/L 203D	1.250	1.250	0.750	6.0	2.000	0.210	1.500	N.. 3	2.750
	NE R/L 164D	1.000	1.000	0.750	6.0	2.000	0.294	1.375	N.. 4	1.540
	NE R/L 204D	1.250	1.250	0.750	6.0	2.000	0.294	1.625	N.. 4	2.750

Ref.					
	NE R/L 062	TF-75	TF-74	1291	5124
	NE R/L 082J	TF-75	TF-74	1291	5124
	NE R/L 102B	TF-75	TF-74	1291	5124
	NE R/L 122B	TF-75	TF-74	1291	5124
	NE R/L 123B	TF-73	TF-72	1297	5004
	NE R/L 163D	TF-73	TF-72	1297	5004
	NE R/L 203D	TF-73	TF-72	1297	5004
	NE R/L 164D	TF-73	TF-72	1297	5004
	NE R/L 204D	TF-73	TF-72	1297	5004

	N..	D	A	T	
 	Ref. N.. 2	0.187	0.219	0.150	NG: Insert for parting NR: Insert for parting with radius NT: Insert for threading For more information see page: E.03/04
	N.. 3	0.375	0.344	0.195	
	N.. 4	0.375	0.453	0.255	
	NG	NR	NT		

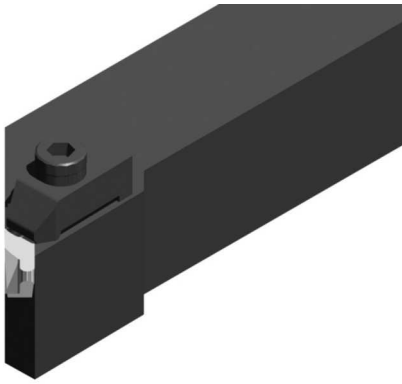

Characteristics:

Specific application grooving toolholder. Right tools require left inserts and vice versa. Maximum grooving depth depending on insert.

Applications:

External grooving toolholder.

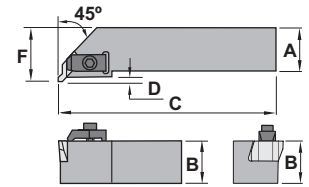

NR								
POSITIVE RAKE		A	B	C	D	F	Insert size	
Ref.	NR R/L 123B	0.750	0.750	4.5	1.250	1.000	N.. 3	0.880
	NR R/L 163D	1.000	1.000	6.0	1.250	1.250	N.. 3	1.540
	NR R/L 203D	1.250	1.250	6.0	1.375	1.500	N.. 3	2.200
	NR R/L 243D	1.500	1.500	6.0	1.375	2.000	N.. 3	5.830

Ref.		R	L		
Ref.	NR R/L 123B	TF-73	TF-72	1297	5004
	NR R/L 163D	TF-73	TF-72	1297	5004
	NR R/L 203D	TF-73	TF-72	1297	5004
	NR R/L 243D	TF-73	TF-72	1297	5004

NG NR NT	N..		D	A	T	NG: Insert for parting NR: Insert for parting with radius NT: Insert for threading
	Ref.	N.. 3	0.375	0.344	0.195	
	NG	NR	NT			

For more information see page: E.03/04

- Inserts
- General turning
- Parting & grooving
- Notch tools

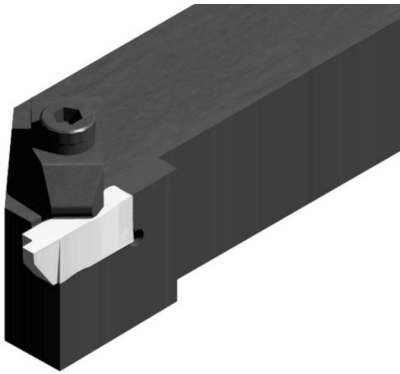

Characteristics:

Multipurpose grooving and threading top clamp toolholder.
Maximum grooving depth depending on insert.

Applications:

External grooving toolholder.

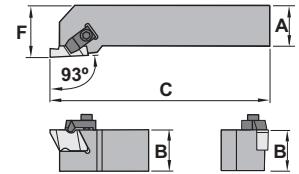

NS								
POSITIVE RAKE		A	B	C	D	F	Insert size	lbs
Ref.	NS R/L 062	0.375	0.375	2.5	0.138	0.562	N.. 2	0.154
	NS R/L 082J	0.500	0.500	3.5	0.138	0.750	N.. 2	0.220
	NS R/L 102B	0.625	0.625	4.5	0.138	0.875	N.. 2	0.440
	NS R/L 122B	0.750	0.750	4.5	0.138	1.000	N.. 2	0.880
	NS R/L 162D	1.000	1.000	6.0	0.138	1.250	N.. 2	1.540
	NS R/L 123B	0.750	0.750	4.5	0.210	1.000	N.. 3	0.880
	NS R/L 163C	1.000	1.000	5.0	0.210	1.250	N.. 3	1.540
	NS R/L 163D	1.000	1.000	6.0	0.210	1.250	N.. 3	1.540
	NS R/L 203D	1.250	1.250	6.0	0.210	1.500	N.. 3	2.750
	NS R/L 164C	1.000	1.000	5.0	0.294	1.250	N.. 4	1.540
	NS R/L 164D	1.000	1.000	6.0	0.294	1.250	N.. 4	1.540
	NS R/L 204D	1.250	1.250	6.0	0.294	1.500	N.. 4	2.750
	NS R/L 244D	1.500	1.500	6.0	0.294	1.750	N.. 4	3.800

Ref.	NS R/L 062	NS R/L 082J	NS R/L 102B	NS R/L 122B	NS R/L 162D	NS R/L 123B	NS R/L 163C	NS R/L 163D	NS R/L 203D	NS R/L 164C	NS R/L 164D	NS R/L 204D	NS R/L 244D
	TF-74	TF-74	TF-74	TF-74	TF-74	TF-72	TF-72	TF-72	TF-72	TF-72	TF-72	TF-72	TF-72

Ref.	N..	D	A	T				
	N.. 2	0.187	0.219	0.150				
N.. 3	0.375	0.344	0.195					
N.. 4	0.375	0.453	0.255					
	NG	NR	NT					

NG: Insert for parting
NR: Insert for parting with radius
NT: Insert for threading

For more information see page: E.03/04

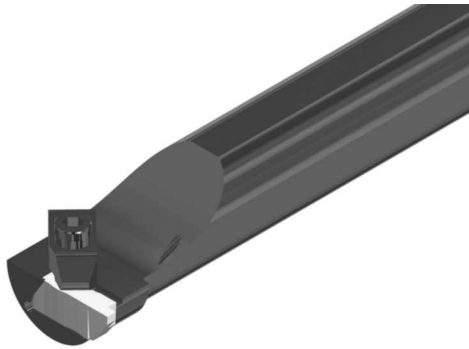

Characteristics:

Multipurpose grooving and threading top clamp boring bar. Right tools require left inserts and vice versa. Maximum grooving depth depending on insert.

Applications:

Internal grooving toolholder.

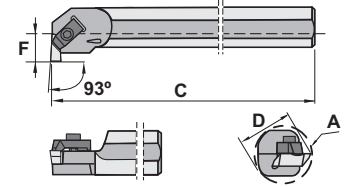

NNTO 93°		A	C	D	F	Insert size	lbs
Ref.	A10S NNTO R/L 2	1.000	10.0	0.625	0.500	N.. 2	0.440
	A12S NNTO R/L 2	1.125	10.0	0.750	0.562	N.. 2	0.880
	A16T NNTO R/L 2	1.375	12.0	1.000	0.688	N.. 2	1.540
	A16T NNTO R/L 3	1.375	12.0	1.000	0.688	N.. 3	1.540
	A20U NNTO R/L 3	1.750	14.0	1.250	0.875	N.. 3	3.080
	A24U NNTO R/L 3	2.000	14.0	1.500	1.000	N.. 3	5.830
	A28U NNTO R/L 3	2.250	14.0	1.750	1.125	N.. 3	5.830
	A28U NNTO R/L 4	2.500	14.0	1.750	1.250	N.. 4	5.830
	A32V NNTO R/L 4	2.750	16.0	2.000	1.375	N.. 4	11.880

Ref.						
	TF-147	TF-146	TF-75	TF-74		
A10S NNTO R/L 2	TF-147	TF-146	TF-75	TF-74	1291	5124
A12S NNTO R/L 2	TF-75	TF-74	TF-75	TF-74	1291	5124
A16T NNTO R/L 2	TF-75	TF-74	TF-75	TF-74	1291	5124
A16T NNTO R/L 3	TF-73	TF-72	TF-73	TF-72	1297	5004
A20U NNTO R/L 3	TF-73	TF-72	TF-73	TF-72	1297	5004
A24U NNTO R/L 3	TF-73	TF-72	TF-73	TF-72	1297	5004
A28U NNTO R/L 3	TF-73	TF-72	TF-73	TF-72	1297	5004
A28U NNTO R/L 4	TF-73	TF-72	TF-73	TF-72	1297	5004
A32V NNTO R/L 4	TF-73	TF-72	TF-73	TF-72	1297	5004

Ref.	N..	D	A	T	NG: Insert for parting NR: Insert for parting with radius NT: Insert for threading
	N.. 2	0.187	0.218	0.150	
N.. 3	0.375	0.344	0.195		
N.. 4	0.375	0.453	0.255		
	NG	NR	NT		

For more information see page: E.03/04

Machining Guidelines for Chip Control - Grooving

- Center height of insert should be positioned at the center of the workpiece, or up to 0.005 inch above.
- Dwell time in the bottom of the groove, more than three revolutions, is not recommended.
- Chip control is feed rate related, and should be adjusted to fit the particular situation. Recommended feed range is 0.003-0.012 ipr/rev).

Machining Guidelines for Chip Control Turning / Profiling

Maximum depth of cut for side cutting (turning / profiling) depends upon material being cut and width of the tool. However, some general guidelines are:

- 1) 0.031 - 0.062 inch wide insert can cut up to 0.025 inch deep.
- 2) 0.067 - 0.128 inch wide insert can cut up to 0.040 inch deep.
- 3) 0.138 - 0.189 inch wide insert can cut up to 0.080 inch deep.
- 4) 0.197 - 0.375 inch wide insert can cut up to 0.120 inch deep.

Groove Limits

Maximum Internal Groove Depth Versus Minimum Bore Diameter

INSERT	MAXIMUM GROOVE DEPTH		MINIMUM BORE DIAMETER					
	inch	mm	inch	mm				
NG-1094L	0.075	1,91	0.800	20,32				
	0.040	1,02	0.440	11,18				
NG-2031R/L	0.050	1,27	0.730	18,54				
NG-2041R/L								
NG-2047R/L								
NG-2058R/L								
NG-2062R/L	0.110	2,79	2.500	63,50				
	0.102	2,59	1.750	44,45				
	NG-2094R/L	0.098	2,49	1.500	38,10			
	NG-2125R/L	0.080	2,03	1.000	25,40			
		0.055	1,40	0.730	18,54			
NG-3047R/L	0.094	2,39	1.750	44,45				
NG-3062R/L								
NG-3072R/L					0.090	2,29	1.625	41,28
NG-3078R/L					0.075	1,91	1.375	34,93
NG-3088R/L								
NG-3094R/L	0.150	3,81	2.375	60,33				
NG-3097R/L								
NG-3105R/L								
NG-3110R/L					0.145	3,68	2.125	53,98
NG-3122R/L	0.138	3,51	1.875	47,63				
NG-3125R/L								
NG-3142R/L	0.125	3,18	1.625	41,28				
NG-3156R/L								
NG-3178R/L								
NG-3185R/L					0.110	2,79	1.375	34,93
NG-3189R/L								
NG-4125R/L	0.150	3,81	2.750	69,85				
NG-4189R/L	0.250	6,35	5.750	146,05				
	0.245	6,22	5.000	127,00				
	NG-4213R/L	0.240	6,10	4.500	114,30			
	NG-4219R/L	0.218	5,54	3.250	82,55			
	NG-4250R/L	0.200	5,08	2.500	63,50			

* The same maximum groove depth and minimum bore diameter values also apply to metric, NG-K (chip control), and NR (full radius) inserts of similar size.

Finish turning the groove

1. Plunge both sides of groove width.
2. Plunge center area to remove web of material remaining.
3. To avoid insert chipping and to achieve groove wall perpendicularity, follow the tool path outlined here.
4. Use the lightest depth of cut that still allows good chip breaking, tool life, and surface finish.

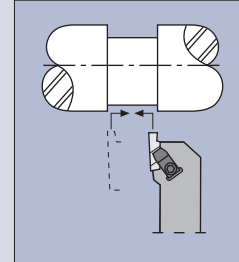

Maximum Internal Groove Depth Versus Minimum Bore Diameter

INSERT	MAXIMUM GROOVE DEPTH		MINIMUM BORE DIAMETER		
	inch	mm	inch	mm	
NG-5250R/L	0.375	9,53	28.812	731,82	
	0.361	9,17	15.812	401,62	
	NG-5281R/L	0.344	8,74	10.812	274,62
	NG-5312R/L	0.327	8,31	7.312	185,72
	NG-5344R/L	0.294	7,47	4.812	122,22
	NG-5375R/L	0.257	6,53	3.562	90,47
	0.215	5,46	2.812	71,42	
NG-6250R/L	0.250	6,35	5.750	146,05	
NG-6281R/L	0.245	6,22	5.000	127,00	
NG-6312R/L	0.240	6,10	4.500	114,30	
NG-6344R/L	0.218	5,54	3.250	82,55	
NG-6375R/L	0.200	5,08	2.500	63,50	

Internal Groove Depth Versus bar Interference

1. Plunge both sides of groove width.
2. Plunge center area to remove web of material remaining.
3. To avoid insert chipping and to achieve groove wall perpendicularity, follow the tool path outlined here.
4. Use the lightest depth of cut that still allows good chip breaking, tool life, and surface finish.

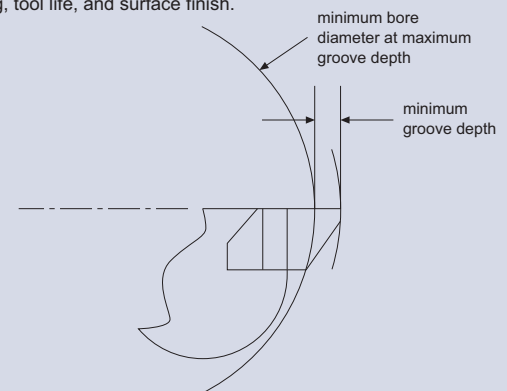

NOTE: Internal grooving depth limits are a function of bar clearance versus bore diameters.

Machining Guidelines for Face Grooving Operations - External

Standard NF/NFD Inserts				
INSERT	MAXIMUM GROOVE DEPTH "B"		MINIMUM GROOVE DIAMETER "C"	
	inch	mm	inch	mm
NF-3	0.060	1,52	0.940	23,9
NF-3	0.094	2,39	1.200	30,5
NF-3	0.125	3,18	1.420	36,1
NF-3	0.150	3,81	1.630	41,3
NFD-3	0.250	6,35	1.880	47,6
NF-4/6	0.060	1,52	0.940	23,9
NF-4/6	0.094	2,39	1.200	30,5
NF-4/6	0.125	3,18	1.420	36,1
NF-4/6	0.150	3,81	1.630	41,3
NF-4/6	0.188	4,78	1.880	47,6
NF-4/6	0.250	6,35	2.250	57,2
NFD-4	0.375	9,53	2.250	57,2
NFD-4	0.500	12,70	2.250	57,2

toolholders

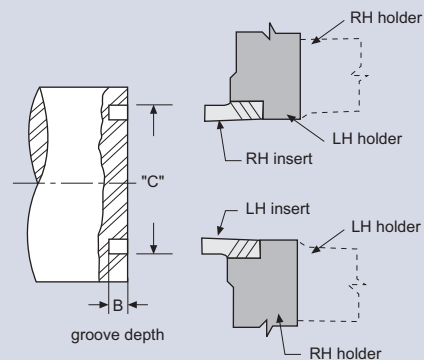

Standard NG/NGD Inserts				
INSERT	MAXIMUM GROOVE DEPTH "B"		MINIMUM GROOVE DIAMETER "C"	
	inch	mm	inch	mm
NG-2	0.050	1,27	2.130	54,0
NG-2	0.110	2,79	3.500	88,9
NG-3	0.094	2,39	4.000	101,6
NG-3	0.125	3,18	5.000	127,0
NG-3	0.150	3,81	5.500	139,7
NGD-3	0.250	6,35	6.880	174,6
NG-4	0.150	3,81	6.000	152,4
NG-4	0.250	6,35	8.250	209,6
NGD-4	0.375	9,53	8.750	222,3
NGD-4	0.500	12,70	8.750	222,3
NG-5	0.375	9,53	13.000	330,2

boring bars

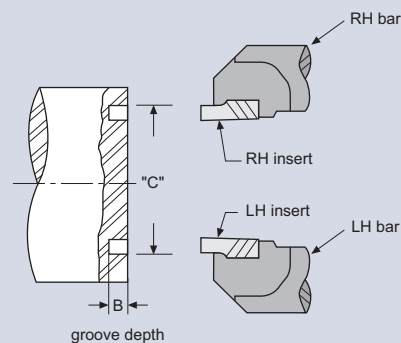

Machining Guidelines for Face Grooving Operations - Internal

Standard NFD Inserts				
INSERT	MAXIMUM GROOVE DEPTH "D"		MINIMUM GROOVE DIAMETER "E"	
	inch	mm	inch	mm
NFD-3-KI	0.250	6,35	2.250	57,2

boring bars

